

Articles

Contribution from the Department of Chemistry and Biochemistry,
The University of Texas at Austin, Austin, Texas 78712-1167

Shape-Selective Intercalation Reactions of Layered Zinc and Cobalt Phosphonates

Guang Cao and Thomas E. Mallouk*

Received September 4, 1990

Dehydration of layered metal phosphonates $M(O_3PCH_3) \cdot H_2O$ ($M = Mg, Zn, Co$) occurs topochemically to give anhydrous salts $M(O_3PCH_3)$ with similar unit cell dimensions in the space group $Pmn2_1$. $Mg(O_3PCH_3)$ absorbs water rapidly from air, forming $Mg(O_3PCH_3) \cdot H_2O$; $Co(O_3PCH_3)$ does so less readily, and $Zn(O_3PCH_3)$ is unreactive even with liquid water. Anhydrous Co and Zn salts $M(O_3PCH_3)$ react with ammonia and primary amines to form intercalation compounds $M(O_3PCH_3)(RNH_2)$, $R = H$ to $n-C_8H_{17}$. The intercalation reaction is shape-selective, as amines with branching at the α -carbon cannot access the metal coordination site. The packing of alkyl chains is different for primary amine intercalation compounds containing Co and Zn . In all $Co(O_3PCH_3)(n-C_nH_{2n+1}NH_2)$ compounds, the chains pack as double layers. In the $Zn(O_3PCH_3)(n-C_nH_{2n+1}NH_2)$ series, compounds with even n also adopt double-layer structures, while odd n compounds form more efficiently packed interdigitated monolayers in the interlamellar region.

Introduction

Layered metal phosphonates have received considerable attention since the late 1970s because of properties which lend themselves to various potential practical uses, such as serving as sorbents, catalysts and catalyst supports, and ion exchangers.¹⁻⁶ All these properties are related to easy access of molecules to the large internal surface area of the layered structures. Since these layered materials have structurally and chemically well-defined internal void spaces and coordination sites and these internal sites are often preparatively easy to alter, in favorable cases so-called "structurally tailored" materials⁷ can be obtained. Examples of structurally tailored materials include pillared tetravalent metal phosphates whose internal surface area becomes accessible upon pillaring.^{4,6} A recent example of this kind of chemistry is the work of Johnson et al.^{5b} who demonstrated shape-selective intercalation of alcohols into vanadyl phosphonates, $VO(O_3PR) \cdot H_2O$. These compounds, prepared by thermal loss of benzyl alcohol from $VO(O_3PR) \cdot H_2O \cdot C_6H_5CH_2OH$, have a vacant coordination site at the V^{IV} atom. A variety of primary alcohols can bind at such sites, while secondary and tertiary alcohols are excluded. $VO-$

Table I. Unit Cell Parameters for $M(O_3PCH_3)$ from Indexing the Powder Patterns in the Orthorhombic System ($Pmn2_1$)

M	cell params, Å		
	a	b	c
Mg	5.44 (1)	6.97 (1)	5.23 (1)
Zn	5.42 (1)	6.94 (1)	5.22 (1)
Co	5.44 (1)	6.85 (1)	5.24 (1)

$(O_3PR) \cdot H_2O$ exhibits this selectivity in absorbing alcohols because of the steric constraints imposed by the R groups of the phosphonate surrounding the binding site.

In continuing our studies of divalent metal phosphonates $M^{II}(O_3PR) \cdot H_2O$, we have found that they can be dehydrated and that the resulting dehydrated phosphonates remain crystalline. In some favorable cases the dehydrated phases remain in the same space group as the initial starting materials and have similar unit cell dimensions. These topochemically dehydrated metal phosphonates show shape selectivity in forming intercalation compounds; i.e., only primary amines are absorbed, while amines with branching at the α -position are excluded. The new intercalation compounds have the general formula $M^{II}(O_3PR) \cdot (RNH_2)$. In a parallel study, Frink et al. have found that size-selective intercalation of the closely related anhydrous phenylphosphonates $M^{II}(O_3PC_6H_5)$ ($M = Zn, Co$) occurs. In this case the size of the bonding pocket is restricted by the phenyl rings, so that only ammonia and water, and not larger amines, can intercalate.^{8b}

Experimental Section

Materials and Methods. Divalent metal phosphonates were synthesized according to literature procedures.⁸ All other chemicals were from commercial sources and were used without purification. Methods and instruments used in the characterization of these compounds are also described in previous publications.^{8b,c,f}

Dehydration of $M(O_3PR) \cdot H_2O$ and Intercalation of Amines into the Resulting Layered Hosts. The dehydration of $M(O_3PR) \cdot H_2O$ ($M = Zn, Co, Ni, Mg$) was carried out in air at temperatures predetermined from TGA experiments. (The measured water loss agrees well with the formulation $M(O_3PR) \cdot H_2O$.) In cases where good crystallinity of the dehydrated phase is desired (e.g., for obtaining indexable X-ray powder

- (1) Mikulski, C. M.; Karayannis, N. M.; Minkiewicz, J. V.; Pytlewski, L. L.; Labes, M. M. *Inorg. Chim. Acta* **1969**, *3*, 523.
- (2) Yamanaka, S. *Inorg. Chem.* **1976**, *15*, 2811.
- (3) (a) Alberti, G.; Constantino, U.; Alluli, S.; Tomassini, J. J. *Inorg. Nucl. Chem.* **1978**, *40*, 1113. (b) Alberti, G.; Constantino, U.; Giovagnotti, M. L. L. *J. Chromatogr.* **1979**, *180*, 45. (c) Casciola, M.; Constantino, U.; Fazzini, S.; Tosoratti, G. *Solid State Ionics* **1983**, *8*, 27.
- (4) (a) Dines, M. B.; DiGiacomo, P. *Inorg. Chem.* **1981**, *20*, 92. (b) Dines, M. B.; DiGiacomo, P.; Callahan, K. P.; Griffith, P. C.; Lane, R.; Cooksey, R. E. In *Chemically Modified Surfaces in Catalysis and Electrocatalysis*; Miller, J., Ed.; ACS Symposium Series 192; American Chemical Society: Washington, DC, 1982; p 223. (c) Dines, M. B.; Griffith, P. C. *Inorg. Chem.* **1983**, *22*, 567. (d) Dines, M. B.; Cooksey, R. E.; Griffith, P. C. *Inorg. Chem.* **1983**, *22*, 1003. (e) Dines, M. B.; Griffith, P. C. *Polyhedron* **1983**, *2*, 607.
- (5) (a) Johnson, J. W.; Jacobsen, A. J.; Brody, J. F.; Lewandowski, J. T. *Inorg. Chem.* **1984**, *23*, 3844. (b) Johnson, J. W.; Jacobsen, A. J.; Butler, W. M.; Rosenthal, S. E.; Brody, J. F.; Lewandowski, J. T. *J. Am. Chem. Soc.* **1989**, *111*, 381. (c) Huan, G.; Jacobsen, A. J.; Johnson, J. W.; Corcoran, E. W., Jr. *Chem. Mater.* **1990**, *2*, 91. (d) Johnson, J. W.; Brody, J. F.; Alexander, R. M.; Pilarski, B.; Katritzky, A. R. *Chem. Mater.* **1990**, *2*, 198.
- (6) (a) Cheng, S.; Peng, G.-Z.; Clearfield, A. *Ind. Eng. Chem. Prod. Res. Dev.* **1984**, *23*, 219. (b) Wan, B.-Z.; Anthony, R. G.; Peng, G. Z.; Clearfield, A. *J. Catal.* **1986**, *101*, 19. (c) Clearfield, A. In *Design of New Materials*; Clearfield, A., Cocke, D. A., Eds.; Plenum: New York, 1986; p 121. (d) Peng, G.-Z.; Clearfield, A. *J. Inclusion Phenom.* **1988**, *6*, 49. (e) Clearfield, A. *Chem. Rev.* **1988**, *88*, 125. (f) Yang, C.-Y.; Clearfield, A. *Reactive Polym.* **1987**, *5*, 13. (g) Colon, J. L.; Yang, C. Y.; Clearfield, A.; Martin, C. R. *J. Phys. Chem.* **1988**, *92*, 5777.
- (7) Mallouk, T. E.; Lee, H. *J. Chem. Educ.* **1990**, *67*, 829.

- (8) (a) Cunningham, D.; Hennelly, P. J. D.; Deeney, T. *Inorg. Chim. Acta* **1979**, *37*, 95. (b) Cao, G.; Lee, H.; Lynch, V. M.; Mallouk, T. E. *Inorg. Chem.* **1988**, *27*, 2781. (c) Cao, G.; Lee, H.; Lynch, V. M.; Mallouk, T. E. *Solid State Ionics* **1988**, *26*, 63. (d) Martin, K.; Squattrito, P. J.; Clearfield, A. *Inorg. Chim. Acta* **1989**, *155*, 7. (e) Ortiz-Avila, Y.; Rudolf, P.; Clearfield, A. *Inorg. Chem.* **1989**, *28*, 2147. (f) Cao, G.; Lynch, V. M.; Swinnea, J. S.; Mallouk, T. E. *Inorg. Chem.* **1990**, *29*, 2112. (g) Frink, K. J.; Wang, R.-C.; Colon, J. L.; Clearfield, A. Following article in this issue.

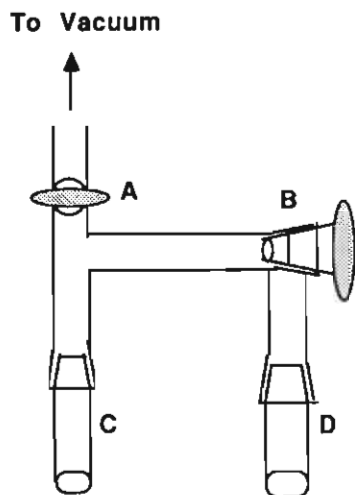

Figure 1. Apparatus used in the dehydration and subsequent intercalation reactions of $M(O_3PCH_3) \cdot H_2O$.

Table II. X-ray Powder Diffraction Data for $Zn(O_3PCH_3)$ (Orthorhombic; $a = 5.425$ (2) Å, $b = 6.938$ (3) Å, $c = 5.221$ (3) Å)

d_{obs} , Å	d_{calc} , Å	hkl	I_{rel}	d_{obs} , Å	d_{calc} , Å	hkl	I_{rel}
6.93	6.94	010	100	2.547	2.550	121	12.6
4.277	4.274	110	10.7	2.445	2.443	012	3.7
4.175	4.172	011	9.8	2.119	2.114	031	3.8
3.761	3.762	101	1.1	2.088	2.086	022	2.7
3.469	3.469	020	3.5	1.971	1.970	131	10.3
3.301	3.307	111	15.3	1.746	1.750	310	1.3
2.930	2.927	120	5.0	1.732	1.731	032	1.4
2.896	2.888	021	4.4	1.654	1.653	222	<1
2.706	2.712	200	3.5	1.608	1.612	113	<1
2.610	2.610	002	3.7				

diffraction patterns), slow heating, at 0.1–5.0 °C/min under nitrogen, gave better results.

In the synthesis of the amine intercalation compounds, anhydrous $M(O_3PR)$ was prepared just before exposure to amine vapor in a reaction system depicted in Figure 1. The monohydrate metal phosphonate was placed in tube C (C and D are tubes with ground glass joints) and was heated in vacuo, while valve B was closed. After dehydration was completed, valve B was opened, and tube D, which contained liquid amine, was briefly pumped to remove air. Valve A was then closed, and the system was held at the appropriate temperature for 1 or several days depending upon the volatility of the amine. In the case of *n*-heptylamine (bp 155 °C) or longer chain *n*-alkylamines, the reaction system was kept at 60–80 °C. The apparent volume of the solid in tube C increased noticeably when amines were absorbed.

Results and Discussion

Structure and Properties of Dehydrated Metal Phosphonates.

As mentioned above, divalent metal phosphonate monohydrates $M(O_3PR) \cdot H_2O$ retain their crystallinity after dehydration. This is true regardless of the identity of either the metal or the R group. In most cases the structural relationship between the dehydrated phase and the monohydrate phase has not been established, because the XRD powder patterns of dehydrated phases are generally complex. However, in favorable cases, e.g., $M = Zn, Co, Mg$ and $R = -CH_3$, the XRD powder patterns can be successfully indexed. Table I lists the unit cell parameters for $M(O_3PCH_3)$, and data from a typical powder pattern, for $Zn(O_3PCH_3)$, are given in Table II. Observed systematic absences are consistent with space group $Pmn2_1$, identical with that of the monohydrate. The onsets of dehydration temperatures were found to vary, from TGA experiments, and are listed in Table III along with the orthorhombic unit cell constants for these compounds.

From the crystallographic data in both Tables I and III, a tentative conclusion may be drawn that the dehydration process for $M(O_3PCH_3) \cdot H_2O$ is topotactic,⁹ since both the monohydrate

Table III. Onsets of Dehydration Temperature and Cell Parameters for $M(O_3PCH_3) \cdot H_2O$ (Indexed in Orthorhombic System, $Pmn2_1$)

M	cell params, Å			dehydration temp (onset), °C
	<i>a</i>	<i>b</i>	<i>c</i>	
Mg	5.68	8.72	4.79	159
Zn	5.68	8.73	4.78	70
Co	5.66	8.69	4.79	155
Ni	5.67	8.68	4.73	260

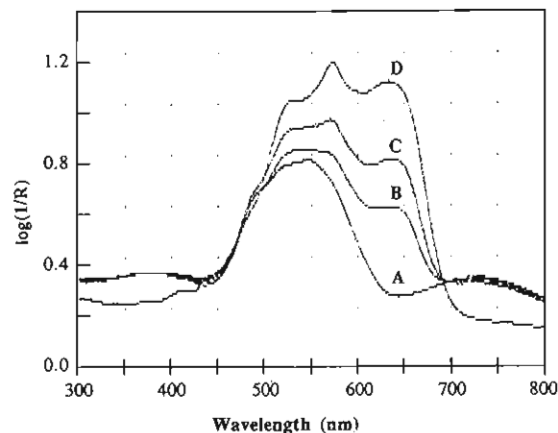

Figure 2. Diffuse-reflectance spectra of $Co(O_3PCH_3) \cdot H_2O$: (A) pure; (B) 32% dehydrated (45 min at 158 °C); (C) 61% dehydrated (75 min at 158 °C); (D) 100% dehydrated ($Co(O_3PCH_3)$) (24 h at 158 °C).

phase and the anhydrous phase are in space group $Pmn2_1$ with similar unit cell dimensions. In the monohydrate phase, the metal ions are octahedrally coordinated by oxygen, with a water molecule occupying one of the coordination sites. These coordination sites are located alternately above and below planes containing the metal ions.^{8b,c,d} The shorter stacking axis, *b*, of anhydrous $M(O_3PCH_3)$ (6.9 Å, compared to 8.7 Å for the monohydrate) may be accounted for by nestling of the methyl group from an adjacent layer into the space vacated by dehydration. This leads to a very efficient space-filling arrangement. Consequently, dehydrated $M(O_3PCH_3)$ is stabilized, and $Zn(O_3PCH_3)$ does not absorb water. However, $Zn(O_3PC_2H_5)$, which is similarly obtained by dehydration but has an almost unchanged layer spacing compared to the monohydrate, absorbs water quickly from the air.

For $M(O_3PCH_3)$ in space group $Pmn2_1$, symmetry requirements¹⁰ will force the phosphonate group and the metal atom to lie in mirror planes, and the coordination number will be 5 for the metal ions. While five-coordination is fairly common for the zinc ion,¹¹ it is rare for Mg^{2+} , Co^{2+} , and Ni^{2+} , which are ordinarily octahedrally coordinated. This trend is consistent with the relatively low temperature observed for dehydration of $Zn(O_3PCH_3) \cdot H_2O$ (Table III). The exceptionally high dehydration temperature of nickel methylphosphonate is the result of a structural change to an unindexed crystalline phase that appears to be layered with an interlayer spacing of 9.96 Å. Also consistent with a coordination number change is the color change, upon dehydration of $Co(O_3PCH_3) \cdot H_2O$, from red-purple to deep blue. Diffuse-reflectance UV-visible spectra tracing the course of dehydration are shown in Figure 2.

The likelihood of five-coordination of metal ions in $M(O_3PCH_3)$ ($M = Co, Zn, Mg$) implies that the dehydration reaction should be reversible. Indeed, it is observed that $Mg(O_3PCH_3)$ and $Co(O_3PCH_3)$ absorb water from the air, the former doing so more rapidly than the latter, to return to the original orthorhombic $M(O_3PCH_3) \cdot H_2O$. As mentioned above, $Zn(O_3PCH_3)$ does not absorb water because of relatively stable five-coordination for Zn^{2+} and the stabilization effect of more efficient packing.

(9) Glasser, L. S. D.; Glasser, F. P.; Taylor, H. F. W. *Q. Rev. Chem. Soc.* **1962**, *16*, 343.

(10) *International Tables for X-ray Crystallography*; Kynoch Press: Birmingham, U.K., 1969, Vol. 1, p 117.

(11) Cotton, F. A.; Wilkinson, G. *Advanced Inorganic Chemistry*, 5th ed.; John Wiley & Sons: New York, 1988; p 598.

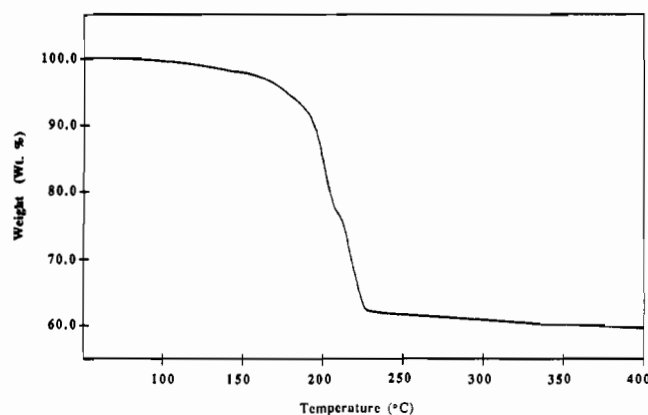

Figure 3. TGA curve for $\text{Co}(\text{O}_3\text{PCH}_3)(\text{C}_6\text{H}_{13}\text{NH}_2)$. Heating rate is 2 $^\circ\text{C}/\text{min}$.

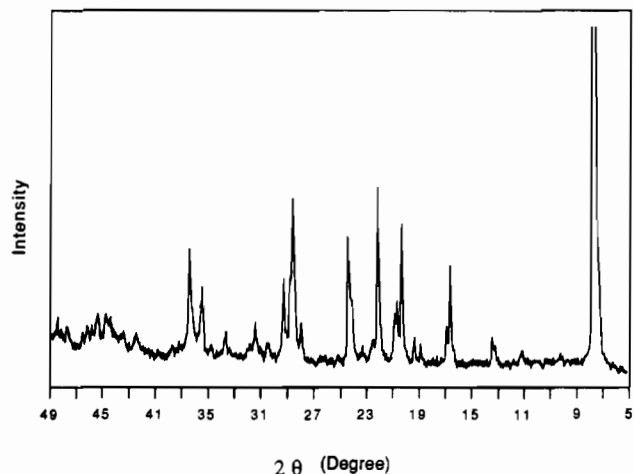

Figure 4. XRD pattern of $\text{Co}(\text{O}_3\text{PCH}_3)(\text{C}_3\text{H}_7\text{NH}_2)$.

$\text{Ni}(\text{O}_3\text{PCH}_3)$ does not absorb water either, because the coordination around Ni^{2+} is most likely octahedral in the anhydrous compound (the color remains green in dehydration from $\text{Ni}(\text{O}_3\text{PCH}_3)\cdot\text{H}_2\text{O}$ to $\text{Ni}(\text{O}_3\text{PCH}_3)$).

Intercalation Reactions of $\text{M}(\text{O}_3\text{PCH}_3)$. In view of the proposed structure for anhydrous $\text{M}(\text{O}_3\text{PCH}_3)$ ($\text{M} = \text{Co}$, Zn , and Mg), it is a logical step to explore their coordinative intercalation chemistry since in these compounds vacant sites for coordination may have been created. What is quite interesting about the anhydrous compounds is that the reactivity of these sites is consistent with trends in the aqueous coordination chemistry of the three metal ions: magnesium methylphosphonate is unreactive with amines but absorbs water most readily, while the other two form intercalation compounds of general formula $\text{M}(\text{O}_3\text{PCH}_3)(\text{RNH}_2)$. $\text{Zn}(\text{O}_3\text{PCH}_3)$ can absorb ethylamine even from 70% aqueous solution to afford $\text{Zn}(\text{O}_3\text{PCH}_3)(\text{C}_2\text{H}_5\text{NH}_2)$, while $\text{Co}(\text{O}_3\text{PCH}_3)$ under similar conditions forms $\text{Co}(\text{O}_3\text{PCH}_3)\cdot\text{H}_2\text{O}$, because of the stronger affinity of Co^{2+} for oxygen-containing ligands such as water. Once formed, however, $\text{Co}(\text{O}_3\text{PCH}_3)(\text{RNH}_2)$ is stable toward moisture in the air. The R group in $\text{M}(\text{O}_3\text{PCH}_3)(\text{RNH}_2)$ ($\text{M} = \text{Co}$, Zn) ranges from H to $n\text{-C}_8\text{H}_{17}$, and the stoichiometry is confirmed by elemental analyses for C, H, and N and by thermogravimetric analysis (TGA). Figure 3 shows a representative TGA weight loss curve, that of $\text{Co}(\text{O}_3\text{PCH}_3)(\text{C}_6\text{H}_{13}\text{NH}_2)$, which illustrates the high stability of these compounds since the amine molecules are not completely volatilized until about 220 $^\circ\text{C}$.

Although the powder XRD patterns of these amine intercalation compounds show well-defined peaks, indicative of a well-ordered structure, they have generally not been indexed due to their complexity. A representative XRD pattern is shown in Figure 4. An exception was found for the ammonia intercalation compound. Pure gaseous ammonia reacts with $\text{Co}(\text{O}_3\text{PCH}_3)$ to afford a purple compound $\text{Co}(\text{O}_3\text{PCH}_3)(\text{NH}_3)$ whose XRD pattern can

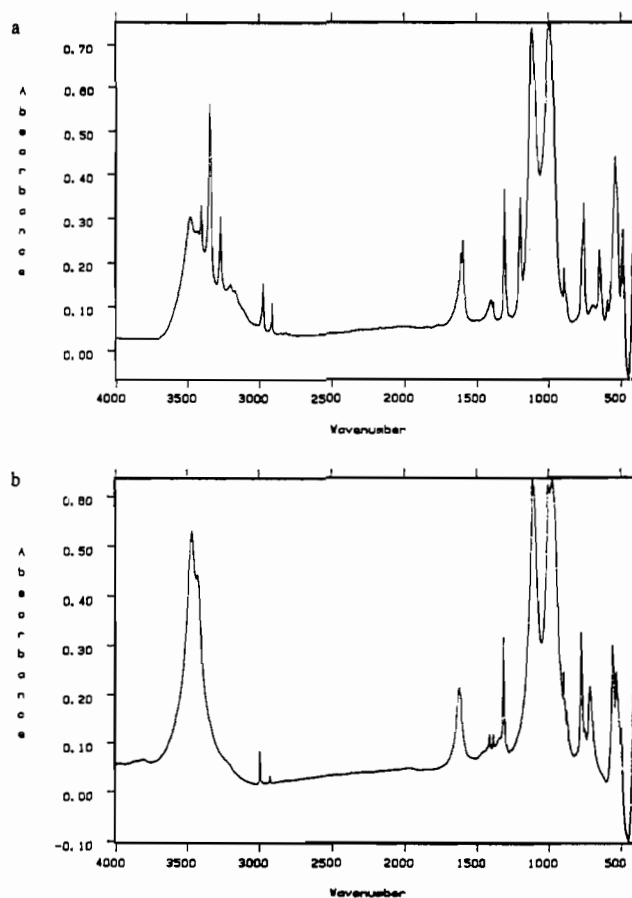

Figure 5. FTIR spectra (KBr pellets) of (a) $\text{Co}(\text{O}_3\text{PCH}_3)(\text{NH}_3)$ and (b) $\text{Co}(\text{O}_3\text{PCH}_3)\cdot\text{H}_2\text{O}$. The broad peak in spectrum a in the OH stretching region comes from a $\text{Co}(\text{O}_3\text{PCH}_3)\cdot\text{H}_2\text{O}$ impurity in the $\text{Co}(\text{O}_3\text{PCH}_3)(\text{NH}_3)$ sample.

be indexed with a set of unit cell constants similar to those of $\text{Co}(\text{O}_3\text{PCH}_3)\cdot\text{H}_2\text{O}$ ($a = 5.89 \text{ \AA}$, $b = 8.92 \text{ \AA}$, and $c = 4.85 \text{ \AA}$ for $\text{Co}(\text{O}_3\text{PCH}_3)(\text{NH}_3)$, compared to $a = 5.67 \text{ \AA}$, $b = 8.69 \text{ \AA}$, and $c = 4.73 \text{ \AA}$ for $\text{Co}(\text{O}_3\text{PCH}_3)\cdot\text{H}_2\text{O}$). The space group of $\text{Co}(\text{O}_3\text{PCH}_3)(\text{NH}_3)$, as determined from systematic absences, is $Pmn2_1$, in which $\text{Co}(\text{O}_3\text{PCH}_3)\cdot\text{H}_2\text{O}$ also crystallizes. Therefore, $\text{Co}(\text{O}_3\text{PCH}_3)(\text{NH}_3)$ must be isostructural with $\text{Co}(\text{O}_3\text{PCH}_3)\cdot\text{H}_2\text{O}$. Further evidence for this comes from the infrared spectrum of $\text{Co}(\text{O}_3\text{PCH}_3)(\text{NH}_3)$, as shown in Figure 5 together with that of $\text{Co}(\text{O}_3\text{PCH}_3)(\text{H}_2\text{O})$. The three absorption peaks in the N–H stretching region and the two absorption peaks in the N–H bending region, together with the splitting pattern of P–O stretchings, are consistent with the required site symmetry of C, for species with $Z = 2$ in space group $Pmn2_1$.¹²

A remarkable feature of the amine intercalation reactions of $\text{M}(\text{O}_3\text{PCH}_3)$ is their shape-selectivity. Experiments in which $\text{M}^{\text{II}}(\text{O}_3\text{PCH}_3)$ ($\text{M} = \text{Co}$ and Zn) were subjected to *n*-butyl-, isobutyl-, *sec*-butyl-, and *tert*-butylamines vapor for prolonged reaction times showed only the formation of intercalation compounds with normal and isobutylamines. This selectivity may be accounted for by considering the structural environment of the water molecule in $\text{M}(\text{O}_3\text{PCH}_3)\cdot\text{H}_2\text{O}$, which is assumed to occupy the amine coordination site. This site is surrounded by four methyl groups, two in the *a* direction about 2.8 Å from the site and two others in the *c* direction about 2.4 Å from the site. Such an arrangement forms a pocket when the water molecule is removed, which is at least partially filled by a methyl group from the adjacent layer. (The layer distance, the *b* axis, in $\text{Co}(\text{O}_3\text{PCH}_3)$ is only 6.85 Å , compared to 8.69 Å for $\text{Co}(\text{O}_3\text{PCH}_3)\cdot\text{H}_2\text{O}$.) Such

(12) (a) Halford, R. S. *J. Chem. Phys.* 1946, 14, 8. (b) Fateley, W. G. *Appl. Spectrosc.* 1973, 27, 395. (c) Fateley, W. G.; McDevitt, N. J.; Bentley, F. F. *Appl. Spectrosc.* 1971, 25, 155.

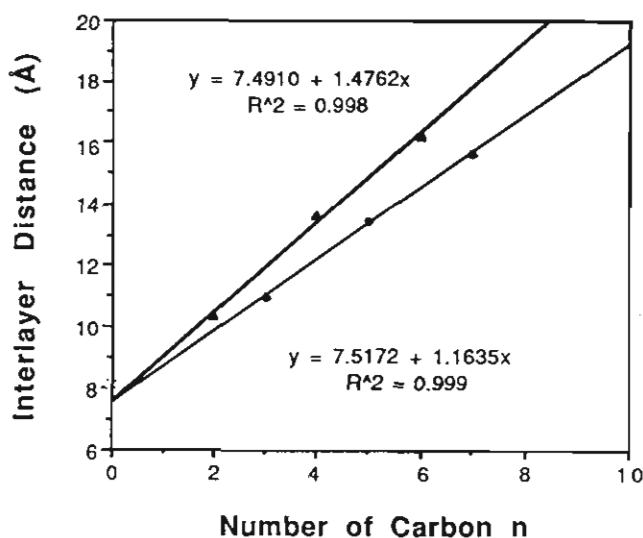
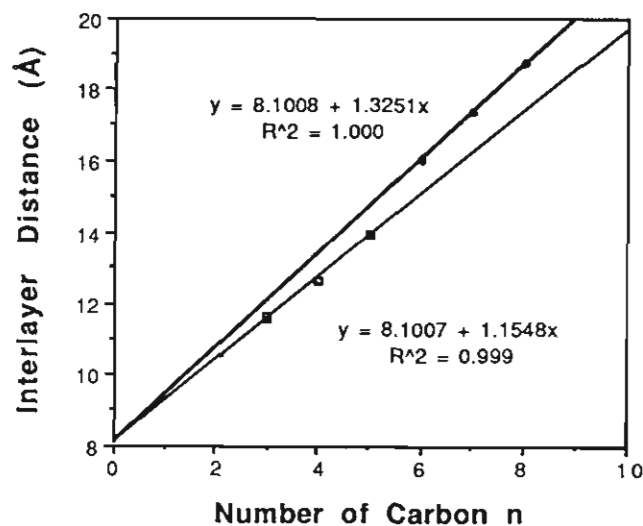

Figure 6. Plots of interlayer distance vs number of carbon atoms in the n -alkyl chain for $M(\text{O}_3\text{PCH}_3)(n\text{-C}_n\text{H}_{2n+1}\text{NH}_2)$: (top) $M = \text{Co}$; (bottom) $M = \text{Zn}$. The equations are the least-squares fits of data connected with straight lines.

a pocket can obviously limit the accessibility of primary amines with branching at the α -position to the metal ion.

Packing of Alkyl Chains in the Series $M(\text{O}_3\text{PCH}_3)(\text{RNH}_2)$. Even though the XRD patterns of $M(\text{O}_3\text{PCH}_3)(\text{RNH}_2)$ have not been indexed, the interlayer spacings of these compounds can be easily determined because the strongest reflections always correspond to the interlayer spacings, characteristic of layered compounds. Table IV gives the interlayer spacings for all of the compounds prepared and the preparation conditions.

Significant structural information about layered compounds that have a series of homologous n -alkyl groups in the interlamellar region can be obtained by plotting the interlayer spacing against the number of carbon atoms in the alkyl group. Shown in Figure 6 are such plots for $M(\text{O}_3\text{PCH}_3)(n\text{-C}_n\text{H}_{2n+1}\text{NH}_2)$ ($M = \text{Co}$ or Zn). For $\text{Co}(\text{O}_3\text{PCH}_3)(n\text{-C}_n\text{H}_{2n+1}\text{NH}_2)$, the interlayer distance increases linearly with a slope of $1.1548 \text{ \AA}/\text{CH}_2$ for $n = 3\text{--}5$ and then with a different slope of $1.3251 \text{ \AA}/\text{CH}_2$ for $n = 6\text{--}8$. The two straight lines intercept at the same interlayer distance of 8.10 \AA at $n = 0$, which is the extrapolated interlayer distance for $\text{Co}(\text{O}_3\text{PCH}_3)(\text{NH}_3)$. While this may imply that there is no difference in the basal structure of the $\text{Co}\text{--}\text{O}\text{--}\text{PCH}_3$ network for all n values in $\text{Co}(\text{O}_3\text{PCH}_3)(n\text{-C}_n\text{H}_{2n+1}\text{NH}_2)$, it certainly indicates that this basal structural network is different from that of $\text{Co}(\text{O}_3\text{PCH}_3)(\text{NH}_3)$ whose interlayer distance is 8.92 \AA . The packing of alkyl chains in these compounds can be inferred from the slope of the linear relation. The slope of $1.3251 \text{ \AA}/\text{CH}_2$ for $n = 6\text{--}8$

Table IV. List of Interlayer Spacings and Preparative Conditions for $M(\text{O}_3\text{PCH}_3)(\text{RNH}_2)$ ($M = \text{Co}$ or Zn)

M, R	$d_{\text{interlayer}}, \text{ \AA}$	prepn conditions
Co, H	8.92	a, b, 1 h
Co, $n\text{-C}_3\text{H}_7$	11.61	a, b, 24 h
Co, $n\text{-C}_4\text{H}_9$	12.63	a, b, 24 h
Co, $i\text{-C}_4\text{H}_9$	11.45	a, b, 2 days, c
Co, $n\text{-C}_5\text{H}_{11}$	13.92	a, b, 2 days
Co, $n\text{-C}_6\text{H}_{13}$	16.06	a, b, 4 days
Co, $n\text{-C}_7\text{H}_{15}$	17.36	a, b, 7 days, c
Co, $n\text{-C}_8\text{H}_{17}$	18.71	70°C , b, 24 h
Zn, C_2H_5	10.32	a, d, 3 h
Zn, $n\text{-C}_3\text{H}_7$	10.97	a, b, 24 h
Zn, $n\text{-C}_4\text{H}_9$	13.64	a, b, 24 h
Zn, $i\text{-C}_4\text{H}_9$	11.33	a, b, 24 h, c
Zn, $n\text{-C}_5\text{H}_{11}$	13.41	a, b, 2 days
Zn, $n\text{-C}_6\text{H}_{13}$	16.23	a, b, 3 days
Zn, $n\text{-C}_7\text{H}_{15}$	15.62	40°C , b, 4 days

^a Room temperature. ^b Over the vapor of pure amine. ^c Incomplete reaction in the indicated time period. ^d Over 70% amine aqueous solution.

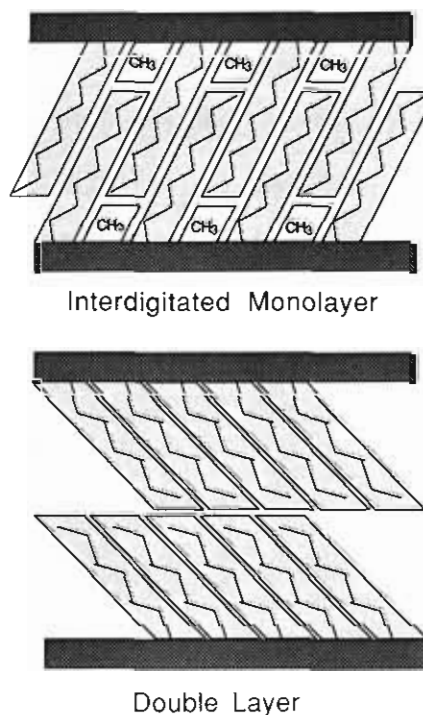

Figure 7. Schematic drawings of interdigitated monolayer and double-layer alkyl chains in amine-intercalated $M(\text{O}_3\text{PCH}_3)$.

being larger than $1.27 \text{ \AA}/\text{CH}_2$ for an all-trans fully extended alkyl chain,¹³ the alkyl chains in these compounds must be arranged as double layers in the interlamellar region, tilted with an angle of $\sin^{-1}(1.3251/2 \times 1.27)$, i.e., 31.4° , with respect to the layer plane. For $n = 3\text{--}6$, however, because the slope $1.1548 \text{ \AA}/\text{CH}_2$ is smaller than 1.27 , it is possible, on one hand, that the alkyl chains from adjacent layers in these compounds are interdigitated, giving rise to a monolayer of alkyl chains that are tilted 65.4° (i.e., $\sin^{-1}(1.1548/1.27)$); on the other hand it is also possible that the alkyl chains still form double layers, only with a very small tilt angle, 27.0° . In the latter case, the abrupt slope increase at $n = 6$ may be explained by the contact of the n th methylene group in one chain with the n th + 5th methylene group in the neighboring chain. This $n, n + 5$ contact, similar to the $n, n + 3$ contact which limits the tilt angle in $M(\text{O}_3\text{PR})\cdot\text{H}_2\text{O}$,^{8b} may conceivably occur only when the tilt angle is very small, as in the present case, and when there are at least six carbons in an n -alkyl chain. Figure 7 shows schematically the structures of intercalated compounds

(13) Kitaigorodskii, A. I. *Molecular Crystals and Molecules*; Academic Press: New York, 1973; pp 48–62.

with interdigitated monolayer and double-layer alkyl chains.

For $Zn(O_3PCH_3)(n-C_nH_{2n+1}NH_2)$, the interlayer distance does not increase with n monotonically, as shown in Figure 6. Close inspection of the data points reveals that all the compounds with an even number of carbon atoms in the amine molecule have interlayer distances that fall on one straight line in the plot, with a slope of $1.4762 \text{ \AA}/CH_2$ and an intercept at $n = 0$ of 7.49 \AA ; those with an odd number of carbon atoms fall on another straight line with a slope of $1.1635 \text{ \AA}/CH_2$ and an intercept of 7.52 \AA at $n = 0$. From these results the packing of alkyl chains can be rationalized as follows: the alkyl chains must be packed as double layers for even values of n and as interdigitated monolayers for odd values of n within the interlamellar region, because the slope of $1.4762 \text{ \AA}/CH_2$ for compounds with even n is greater than $1.27 \text{ \AA}/CH_2$ (vide supra), the slope of $1.1635 \text{ \AA}/CH_2$ is smaller than $1.27 \text{ \AA}/CH_2$ for compounds with odd n , and the $n, n + 5$ contact mentioned previously obviously does not exist for compounds with $n = 3$ or 5 . Therefore the tilt angles for these compounds, calculated accordingly, are 35.5° for compounds with even n and 66.4° for those with odd n . It is interesting to note that the two intercepts differ slightly (7.49 and 7.52 \AA), implying that very

little change in the basal structure ($Zn-O-PCH_3$ network) is involved when the alkyl chains of the amine molecule go from double-layer to single-layer arrangements. In addition, since the two intercepts are significantly smaller than those of $Co(O_3PCH_3)(n-C_nH_{2n+1}NH_2)$ (8.10 \AA), the $M-O-PCH_3$ networks for $M = Co$ and Zn change in considerably different ways upon intercalation with alkylamines.

The odd/even dependence of the single- or double-layer arrangement for $Zn(O_3PCH_3)(n-C_nH_{2n+1}NH_2)$ is not at present understood. It must involve some subtle steric factors that make the more efficient interdigitated monolayer packing of alkyl chains impossible for the intercalation compounds with even n values. To elucidate these factors, more structural work is needed, and model building may prove useful. These studies are currently in progress.

Acknowledgment. This work was supported by grants from the National Institutes of Health (1RO1GM43844-01), the Exxon Education Foundation, and the Robert A. Welch Foundation. T.E.M. also thanks the Camille and Henry Dreyfus Foundation for support in the form of a Teacher-Scholar Award.

Contribution from the Department of Chemistry,
Texas A&M University, College Station, Texas 77843

Intercalation of Ammonia into Zinc and Cobalt Phenylphosphonates

Karen J. Frink, Ren-Chain Wang, Jorge L. Colón, and A. Clearfield*

Received September 7, 1990

$Zn(O_3PC_6H_5) \cdot H_2O$ and $Co(O_3PC_6H_5) \cdot H_2O$ can be easily dehydrated to yield structures that are isomorphous with the corresponding monohydrate. The dehydration is reversible since both derivatives quickly reabsorb moisture from the atmosphere. The dehydration reaction leaves an open coordination site on the metal allowing both anhydrous zinc and cobalt phenylphosphonates to intercalate ammonia upon exposure to a flow of ammonia gas, as evidenced by FTIR, elemental analysis, and TGA data. Carbon dioxide, carbon monoxide, oxygen, propylamine, and ethylene were not similarly intercalated. Computer-simulated calculations indicate that intercalation of molecules larger than NH_3 result in significant overlap of van der Waals surfaces between the intercalate and the phenyl rings.

Introduction

Pillared clays are a new class of porous compounds with potential for many future applications in that they are amenable to incorporation of specific and selective structural features and properties such as acidity, surface area, pore size, redox behavior, and ion exchange.^{1,2} Layered metal phosphonates in one sense may be considered to be pillared since the metal-oxygen portion of the layers may be separated from each other by predicted amounts.³⁻⁶ The spacing of the organic groups on the layer surface depends upon the bite or bridging reach of the phosphonate groups. Generally, this is of the order of 4-5 Å, which is insufficient to allow access to the interlamellar space by reactant molecules. However, the divalent and some trivalent metal phosphonates contain metal-coordinated water molecules that are

readily removed thermally.⁷ This procedure leaves a vacant metal coordination site which may be accessible to other species and serve as reaction sites. This report together with that of Cao and Mallouk¹⁰ presents some details on this feature of the divalent metal phosphonates.

The synthesis of a series of layered divalent metal phenylphosphonates of general formula $M(O_3PR) \cdot H_2O$ was first carried out by Cunningham et al.⁷ They correctly surmised that the metal was octahedrally coordinated but did not provide further structural detail. In several crystal structure studies^{8,9} it was found that these compounds form zigzag layers in which two phosphonate oxygens chelate the metal and at the same time bridge to other metals. The third oxygen is only two-coordinate, being involved in bridging a metal center. The sixth metal coordination site is occupied by the water molecule.

Cunningham⁷ also reported that the coordinated water can be removed upon heating to leave a vacant coordination site. Cao and Mallouk¹⁰ show that the resulting dehydrated phosphonates remain crystalline and in some cases retain the same space group

- (1) Pillared Clays. Special issue of *Catal. Today* **1988**, 2, 185 ff.
- (2) Clearfield, A. In *Surface Organometallic Chemistry, Molecular Approaches to Surface Catalysis*; Basset, J. M., Gates, B. C., Candy, J. P., Chaplin, A., Laconte, M., Quignard, F., Santini, C., Eds.; Kluwer Academic Publishers: Norwell, MA, 1988.
- (3) Alberti, G.; Costantino, U.; Alluli, S.; Tomassini, J. *J. Inorg. Nucl. Chem.* **1978**, 40, 1113.
- (4) Dines, M. B.; Di Giacomo, P. *Inorg. Chem.* **1981**, 20, 92.
- (5) Johnson, J. W.; Jacobsen, A. J.; Brody, J. F.; Lewandowski, J. T. *Inorg. Chem.* **1984**, 23, 3844.
- (6) Clearfield, A. In *Design of New Materials*; Cocke, A., Clearfield, A., Eds.; Plenum: New York, 1986.

- (7) Cunningham, D.; Hennelly, P. J. D.; Deeney, T. *Inorg. Chim. Acta* **1979**, 37, 95.
- (8) Cao, G.; Lee, H.; Lynch, V. M.; Mallouk, T. E. *Inorg. Chem.* **1988**, 27, 2781.
- (9) Martin, K. J.; Squattrito, P. J.; Clearfield, A. *Inorg. Chim. Acta* **1989**, 155, 79.
- (10) Cao, G.; Mallouk, T. E. Previous article in this issue.